



# PWL12V125FT VRLA Battery

## Valve Regulated Lead Acid Battery

Our patented PWL Valve Regulated Lead Acid Battery is designed for telecom and CATV back-up applications.

### Specifications

- Front Access Design
- Grid Alloy: Lead Calcium Tin
- Case/Cover: PPE Resin (Flame Retardant, UL94 V-0, Halogen Free)
- Terminal: M6 Threaded copper terminal

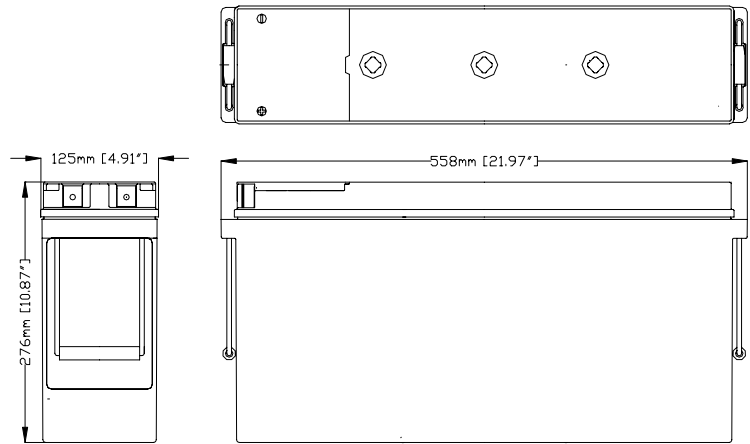

Model	Nominal Voltage (V)	Capacity 8HR (Ah)	Mass	Design Life @ 25 deg. C. (Year)	Dimensions (mm)			
					L	W	H	TH
PWL12V125FT	12	125	110lb 50kg	13	21.97" 558mm	4.91" 125mm	10.87" 276mm	10.23" 260mm

PWL12V125FT Amperes to Final Volts per Cell Temp.: 25 deg. C. ( 77F)											
		Discharge Time (hr)									
F.V.	20	12	10	9	8	7	6	5	4	3	2
1.75	7.11	11.0	12.9	14.1	15.6	17.5	20.0	23.4	28.4	36.3	51.4
1.80	6.90	10.7	12.4	13.6	15.0	16.9	19.1	22.4	27.1	34.5	48.8
1.85	6.64	10.2	11.8	12.9	14.2	15.9	18.2	21.1	25.4	32.4	45.4

Contact : **GS Battery U.S.A. Inc.** <http://www.gsbattery.com/>  
**US Headquarters**  
 1000 Mansell Exchange West, Suite 350  
 Alpharetta GA, 30022

Phone (678) 762-4818  
 Toll Free at (800) 472-2879  
 Fax: (678) 739-2132

# GS Battery (USA)